

FLEX^e™

Ultra Flexible operation Absolute Linear Encoder

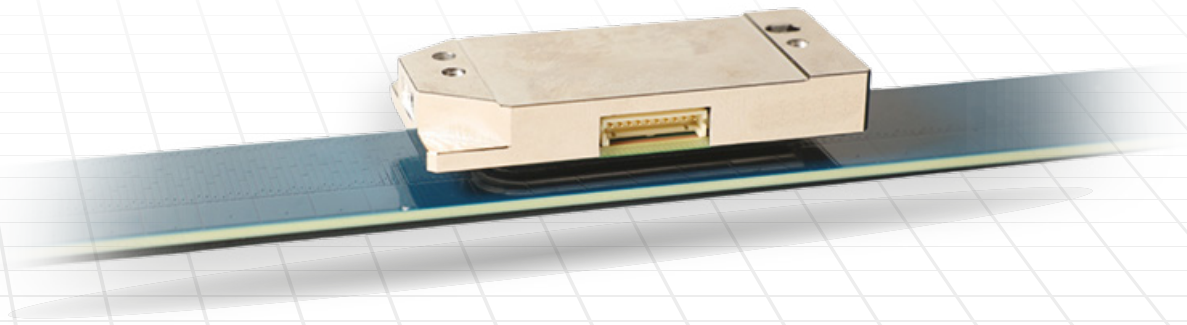

- Extreme lateral Offset
- Extreme Stand-off

- Vibration resilient
- Immune to dust, scratches & Harsh Conditions

KAPPASENSE'S FLEXe™

KappaSense's FLEXe™ is a Series of extremely wide operational range linear encoders using its unique Capacitive Technology. The Active Readhead can operate with high Y & Z tolerances which could be perfect for operations in vibrating environment.

The FLEXe™ encoder excels in tough environment conditions.

High temperature, dirt & even Scratches, will not prevent it from providing accurate measurement.

The Flex Kit is comprised of the following:

- > Active Scale
- > Active Readhead
- > Remote Electrical module

TECHNICAL SPECIFICATION

Encoder Parameter	Value
Encoder Type	Absolute / Incremental
Encoder Interface	BiSS C / A quad B
Stroke length	Up to 1900 [mm]
Accuracy	±20 [µm] / 1meter
Resolution	2[µm]
Operating Speed	Up to 10 [m/sec]
Operating temp range	-40 ÷ 85 [°C]
Roll, Pitch, Yaw	±1 [Deg]
Lateral offset tolerance	±2.5 mm
Readhead stand-off	2 ±1.5mm

KEY FEATURES

- > Superior installation and operation range
- > Contamination Immunity, dust, grease and more
- > Customizable
- > Resilient to vibration
- > Immunity to magnetic fields
- > Wide temperature range

APPLICATIONS

- > Semiconductors Wafer Handling
- > Machine Automation
- > Printing, Laser & CNC
- > Medical Equipment
- > Linear Motors, Stages & Actuators
- > Challenging environments (Temp, Vibrations Dirt)

MECHANICAL DIMENSIONS

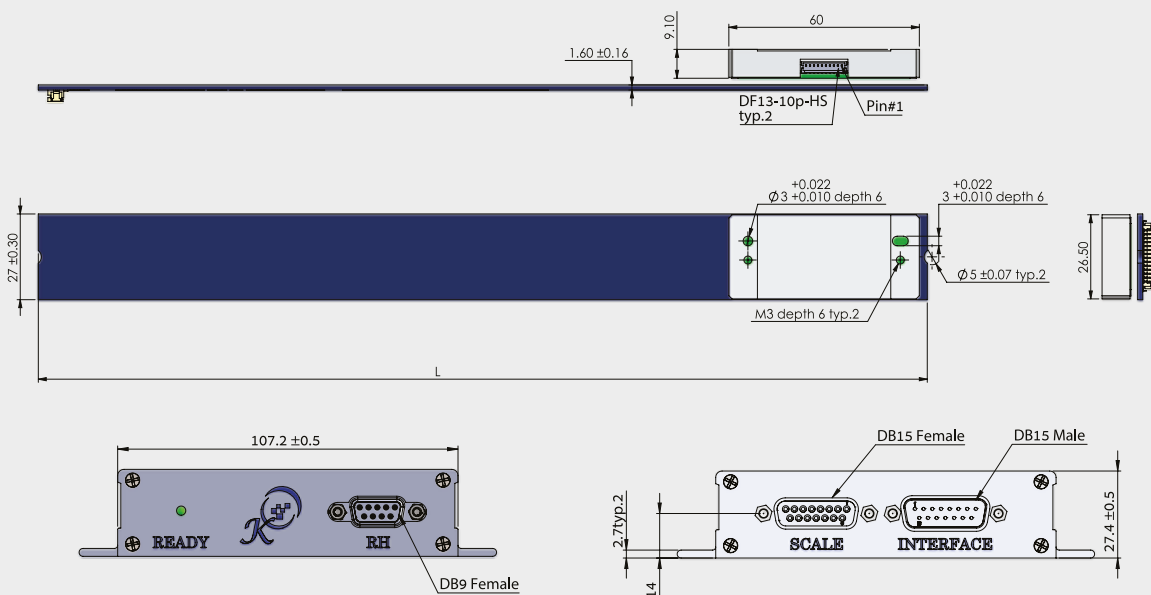

ORDERING INFORMATION

	FLEX	0760	A	B	S	01	001
Description	Product Family	Sacle Length	Sensing	Communication		# of Readheads	Factory Specific
options	Flex	280	A - Absolute	B - BiSS C	S - Standard	01- Single	
		760	I - Incremental*	A - AqB	V - Vacuum*		
		*					

* Contact for Availability

8 Good reasons for choosing KappaSense FLEXe Encoder

- 1 |  Capacitive, Absolute, Linear Encoder
- 2 |  Installation Flexibility
- 3 |  Temperature Range
- 4 |  Immunity to shock & Vibrations
- 5 |  Limited Liquid Sensitivity
- 6 |  No Magnetic Sensitivity
- 7 |  Limited Dust Sensitivity
- 8 |  Field-proven in flagship machine



FLEX^e™

Ultra Flexible operation Absolute Linear Encoder

How can we assist you?
You are always welcome to contact us.



+972-4-6300900



sales@kappasense.com



www.kappasense.com